



IBIPC

INSTITUTE OF BLAST &
IMPACT PROOF CONCRETE



**MADE TO
SAVE YOU!**



**MADE TO
SAVE YOU!**



INTRODUCTORY WORD

Honourable Ladies and Gentlemen,

thank you for your kind attention you give to these rows.

Since 2016, together with scientists from the **Faculty of Civil Engineering at the Czech Technical University in Prague**, with the support of military specialists from the **Department of Engineering Structures at the University of Defence in Brno**, experts from the **Military Research Institute** and our consultants with experience from foreign missions, we have been developing special protective elements, also for your safety. You may encounter them when travelling at airports or large transport hubs, where they are installed to protect soft targets, but mostly their placement is intended for use outside normal traffic, when they are used to protect civilian or critical infrastructure; but their main application is mostly for the defence industry.

The **INSTITUTE OF BLAST & IMPACT PROOF CONCRETE - IBIPC** is one of the leading providers of security solutions that protect people, business and society. It holds the status of an **official NATO catalogized producer**, with the assigned **NCAGE - NATO Commercial and Government Entity identification code 8286G**, with the authority to supply to **North Atlantic Treaty Organization governments**. IBIPC safety elements are assigned a **13-digit NATO STOCK NUMBER** and are manufactured to NATO standards, requirements and specifications, with an "open architecture" design to accommodate specific customer needs.

IBIPC products made of ultra-high strength wire concrete with unique kinetic energy absorption capability, developed in cooperation with researchers and scientists, have been tested and certified Military Research Institute according to **NATO STANAG 2280:2016** for ballistic, blast and shrapnel resistance of the highest values. Design, project and construction are based on the recommendations of the European Commission's SECURITY BY DESIGN concept; their placement in public space does not disturb the overall civilian appearance of the place. The properties declared by the patents have been verified at the **State Testing Laboratory of the Czech Technical University in Prague**. The intellectual and industrial rights of the products are protected by **European patents and industrial designs**.

IBIPC security elements provide a high level of **protection to first strike targets, objects important for national defence, military infrastructure, protect against threats of sabotage and terrorist attack, hybrid attack and attack by professional army**. Newly developed comprehensive range of 22 types of globally unique HI TEC security features brings the ability to respond quickly to defined threats in the event of an **emergency, state of national emergency and state of war**. From security benches to ballistic walls, checkpoints and bunkers with CBRNE filtration system, control release points, inter-operational ammunition bunkers, to hardened aircraft shelters.

IBIPC is a full member of the **Defence Industry Association**, and the **Security Bunker Alliance** group. We are a reliable partner supporting the coherence of common security and defence policy for the **Army, Police, Security Forces and Civil Defence**, especially of **EU and NATO nation states**. We bring strategic autonomy in our projects to our business partners and are open to creative cooperation strengthening international defence relations and ties.

We still believe in honest traditional craftsmanship, skilful handiwork, celebration of human art and the creative spirit of man! These are the cornerstones, on which we with efforts build from our dreams unique products to protect human lives.

I wish you the good luck in your professional and private life! And if you ever find yourself in a difficult security situation near our safety element, I sincerely wish you to stand on the right side.

Yours faithfully

Pavel Belohradsky, CEO



USE OF IBIPC PROTECTION ELEMENTS BASIC BRIEF INFORMATION

- Developed in cooperation with Czech Technical University in Prague and the University of Defence, tested and certified by the Military Research Institute.
- All IBIPC elements have the required certifications according to **NATO STANAG 2280:2016** Edition 2, and comply with the requirements for high protection against small arms, shrapnel and blast levels:
 - **A5** - 14.5 x 114 API M32 projectile,
 - **C4** - 107 mm rocket / 120 mm mortar shell,
 - **D6** - Resistance to 50 kg TNT.
- The Bunker, Shelter and Checkpoint safety elements are fitted with bulletproof ballistic glass according to **NATO STANAG 4569 Level IV**.
- The Bunker, Shelter and Checkpoint safety feature meets adequate conditions to protect the occupants of armoured vehicles in accordance with **NATO STANAG 4569** against kinetic energy strikes, artillery and Improvised Explosive Device **Level IV** explosions.
- Surface of the elements treated with UNIVERSUM CAMOUFLAGE PATTREN primer, optionally eight other camouflage colours according to NATO M.E.R.D.E.C. standard.



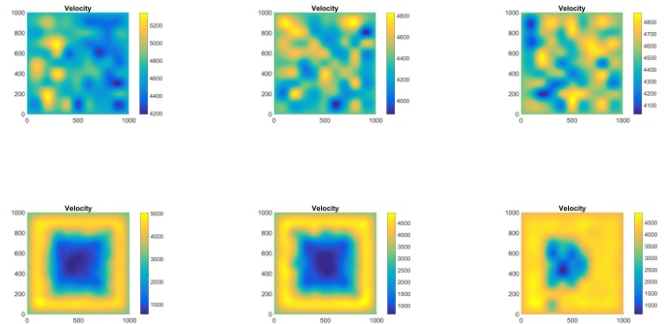

RESEARCH AND DEVELOPMENT.

The safety elements were developed by IBIPC in cooperation with scientists from the Czech Technical University in Prague, the University of Defence and the Military Research Institute, and are protected by international patent rights. They comply with NATO standards and have already been delivered for objects important for national defence, objects of possible attack and for the protection of critical infrastructure.



Laboratories of the Faculty of Civil Engineering CTU.

In the modern laboratories of the Faculty of Civil Engineering, CTU Prague, samples made of HI TECH composite ULTRA HIGH PERFORMANCE FIBER REINFORCED CONCRETE - UHPFRC were developed and tested for several years. Through research and efforts of leading scientists, unique physical-mechanical properties of highly durable UHPFRC were achieved.



Faculty of Military Engineering

The scientific research activities of the specialists of the Faculty of Military Engineering were focused on the needs of the defence industry, troops and state entities, especially in the areas of protection, design and construction of critical and military infrastructure, diagnostics of building structures and military engineering technology. Scientists, technicians, experts, specialists and expert military advisors with practical experience from foreign missions have been involved in the development of the safety element solutions.



Military Research Institute

The Military Research Institute (MRI) participated scientifically in the implementation of basic and applied research and experimental development of IBIPC security elements with the aim of enabling the fulfilment of the strategic interests of states in the field of defence, security and capability development, especially of the Army of the Czech Republic and allied armies. MRI participated in final tests, protocols and certifications.



Intellectual property protection.

The intellectual and industrial rights of the UHPFRC are protected by international patents. The rights of the originators of the design solutions of the safety components are also subject to legal protection of intellectual property, and are duly registered with the relevant authorities, including the European Patent Office within the meaning of the law.

BALLISTIC CONCRETE BENCHES.

To strengthen the defence of the inner perimeters of military and civilian airports, protection of foreign embassies, public administration buildings, access roads to urban centres, defence of critical infrastructure, both military and civilian. The safety element is hard to detect under the timber cladding. Provides coverage for reloading and returning fire.



IN LIGHT AND HEAVY VERSION

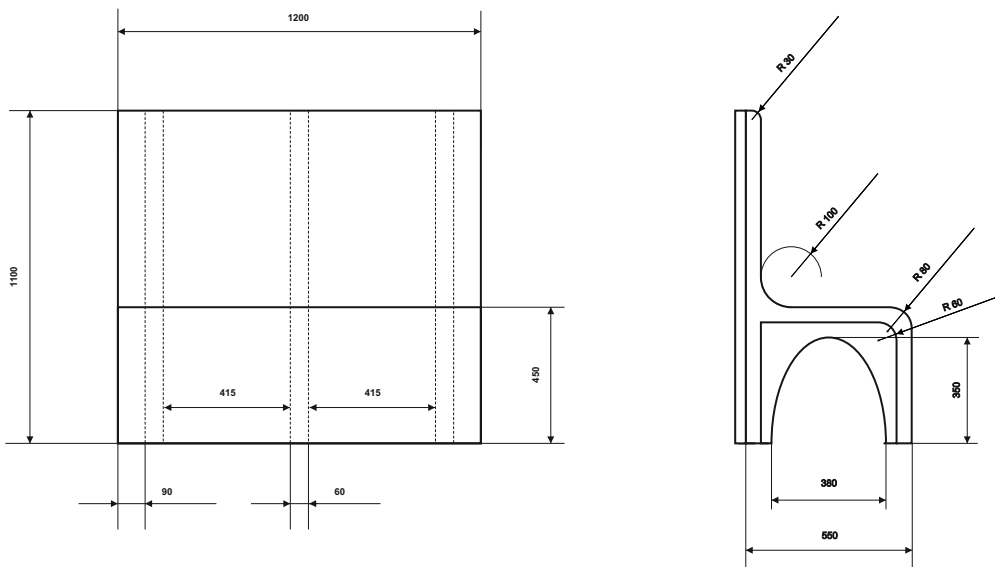

It is characterized by high resistance to the effects of the blast wave and to penetration by conventional projectiles, shrapnel and secondary shrapnel. Captures and diverts pressure wave, prevents the penetration of a passenger vehicle into the protected perimeter.

BALLISTIC CONCRETE FLOWER BOXES.

To strengthen the defence of the inner perimeters of military and civilian airports, protection of foreign embassies, public administration buildings, access roads to urban centres, defence of critical infrastructure, both military and civilian. The safety element is hard to detect under the timber cladding. Provides coverage for reloading and returning fire.



IN LIGHT, HEAVY AND TRUCK

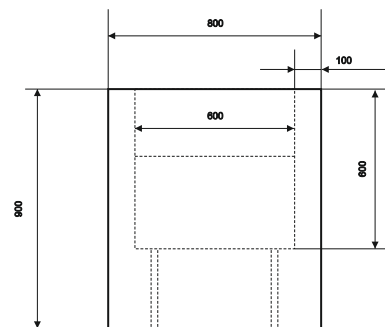
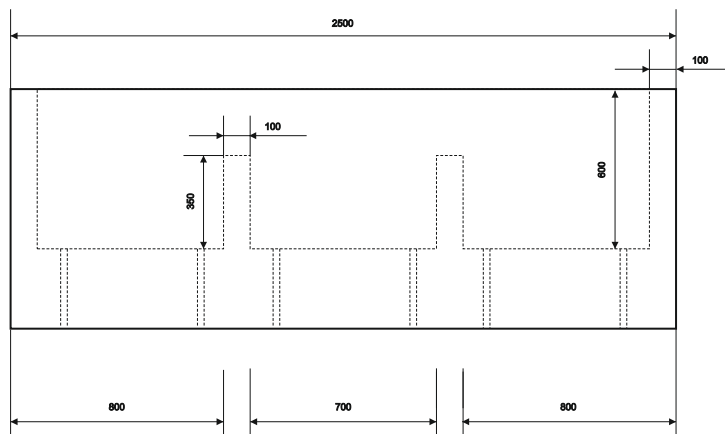
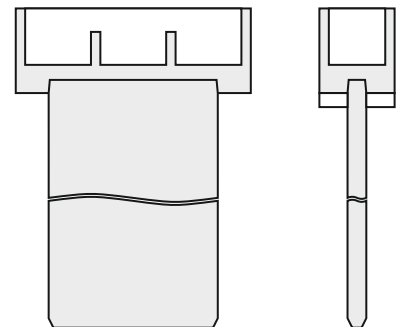

Either freestanding only the top part of the element, or placed on a plate based in the ground. The combination of the two parts, designed according to an explicit numerical simulation, has the ability to restrain the impact of a 20t truck driving at 100km/h.

BALLISTIC SEATS.

To strengthen the defence of the inner perimeters of military and civilian airports, protection of foreign embassies, public administration buildings, access roads to urban centres, defence of critical infrastructure, both military and civilian. The safety element is hard to detect under the timber cladding. Provides coverage for reloading and returning fire.

IN LIGHT AND HEAVY

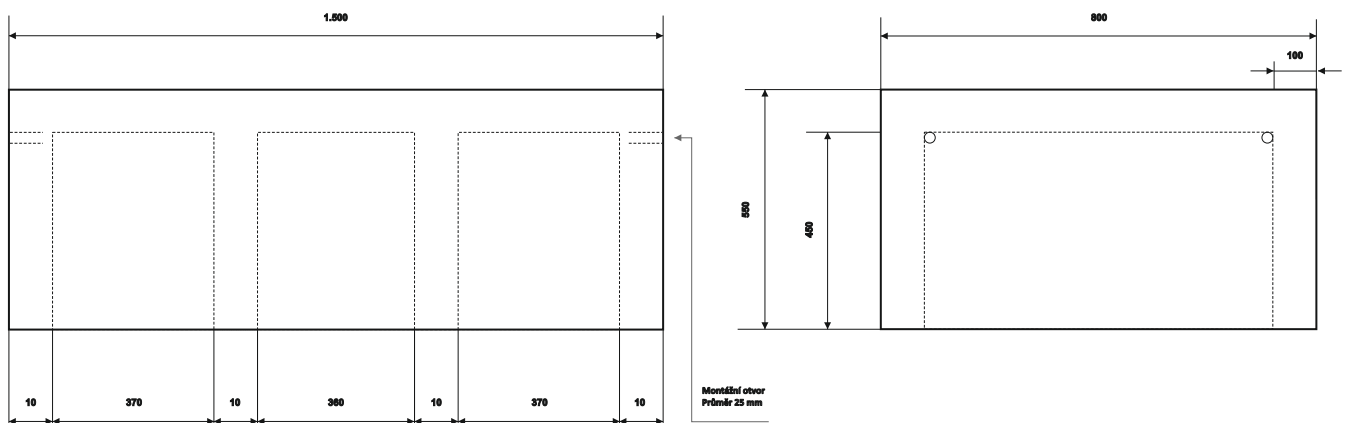
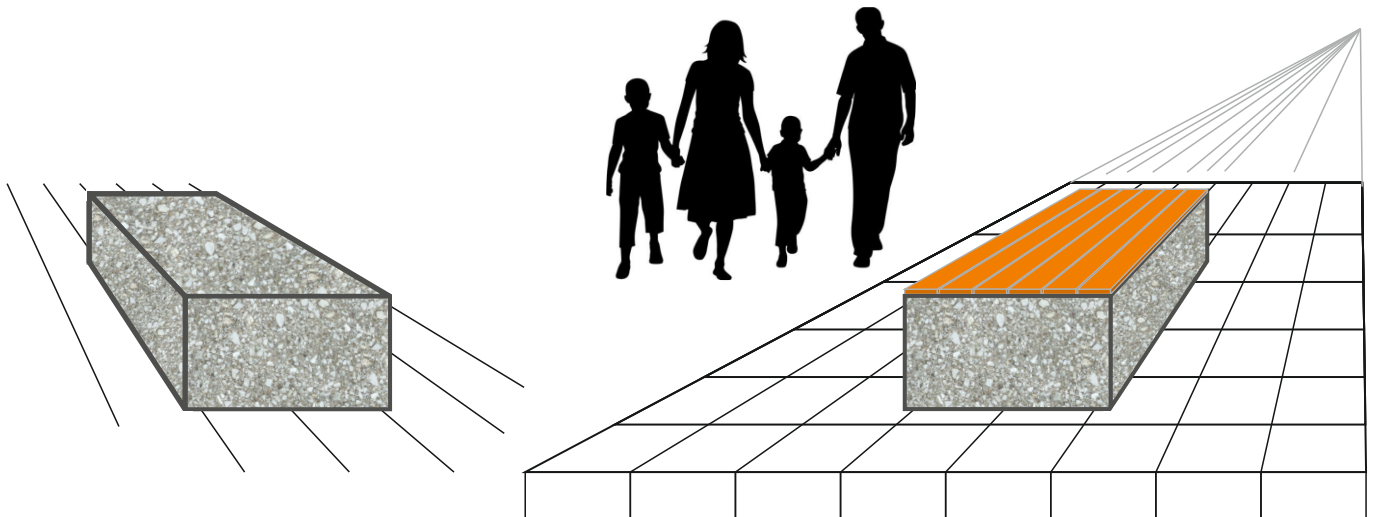

It is characterised by high resistance to the effects of blast pressure waves and to penetration by conventional projectiles, shrapnel and secondary shrapnel. Captures and diverts pressure wave. When anchored, it prevents a passenger vehicles from penetrating into the protected perimeter.

BALLISTIC WALLS.

A. Protection of military infrastructure.

- Aircraft shelters, flight control stations, command posts, radar systems, aviation fuel depots, air defence stations and other selected airport infrastructure facilities.
- Ammunition depots, fuel depots, combat equipment parks, air defence sites, command facilities and other important ground infrastructure facilities.

B. Protection of civil infrastructure.

- Power plants, transformer stations, important population supply depots, drinking water supplies, hospitals and their backup generators, and other important civil infrastructure facilities.

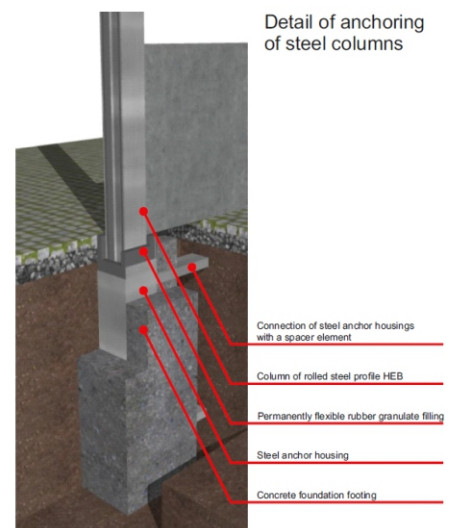

UNIVERSAL CONSTRUCTION SEGMENT. BUNKERS, SHELTERS, CHECKPOINTS.

- Durability, simplicity, resiliency, and unusually long life. These are the key design attributes of IBIPC's high quality prefabricated space frame with a lock that creates a watertight joint when the seal is fitted. A simple and reliable system of reinforced concrete elements made from UHPFRC to create mobile Bunkers, CD Shelters, Checkpoints and other elements. In several dimensions and construction lengths.
- Ventilation system functional even in case of a state of war when electricity is not available; manual and electrically powered unit. Filtration and ventilation equipment to supply the protected area with air even under WMD conditions. In a collective protection facility, it creates an overpressure that prevents the penetration of harmful substances into the protected crew compartment.
- All elements and components to be modularly deployable without the need for routine maintenance. Designed to be flexible in the assembly needed to meet current requirements.
- Technical data of the basic Universal Building Segment: length $L = 2$ m, clear width and height $W*H = 2*2.1$ m, overall width*height $2.4*2.5$ m, wall thickness 0.2 m, weight 9,5 tonnes.

The Ministry of Defence and the Army of the Czech Republic have the element registered as BUNKR IBIPC under the number S-22802016, Material Classification Number 014541000544, ID A492H04BAYR6.

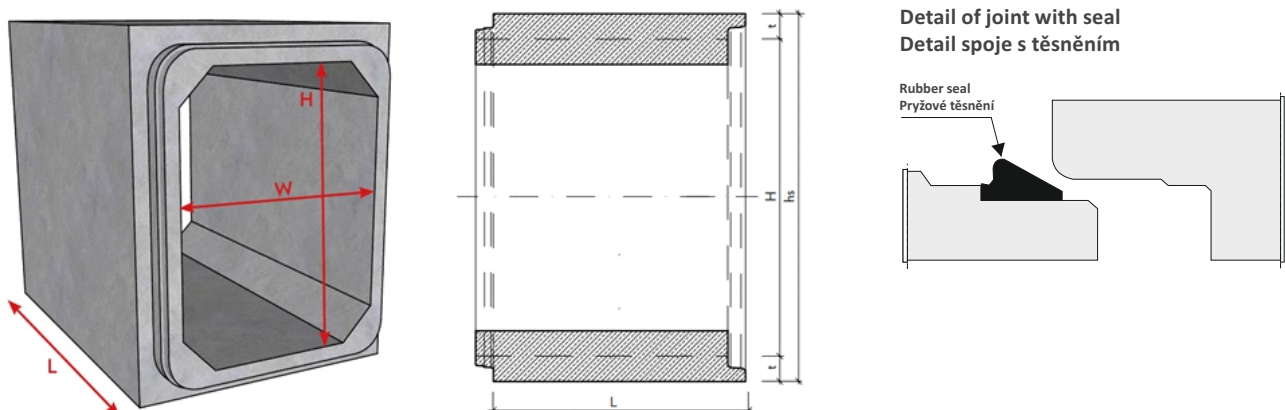

CHECKPOINTS.

To strengthen the defence of the state border, reinforce the outer perimeters of military and civilian airports, reinforce the defence of bridges and important transit arteries, reinforce the defence of critical and civilian infrastructure.

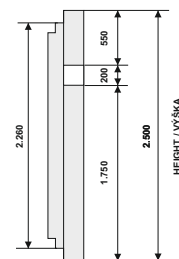
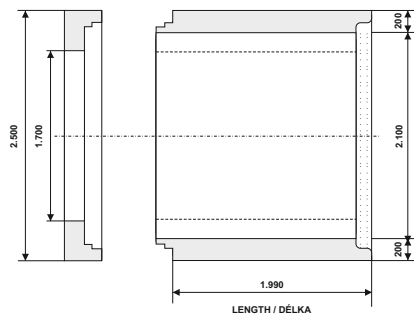
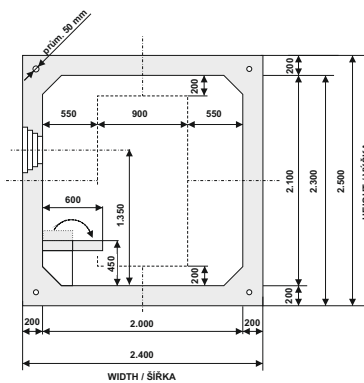
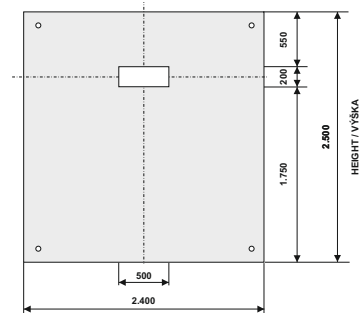
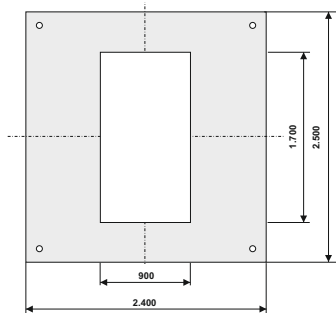
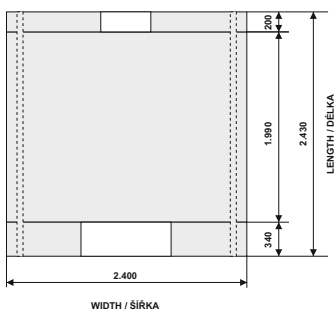
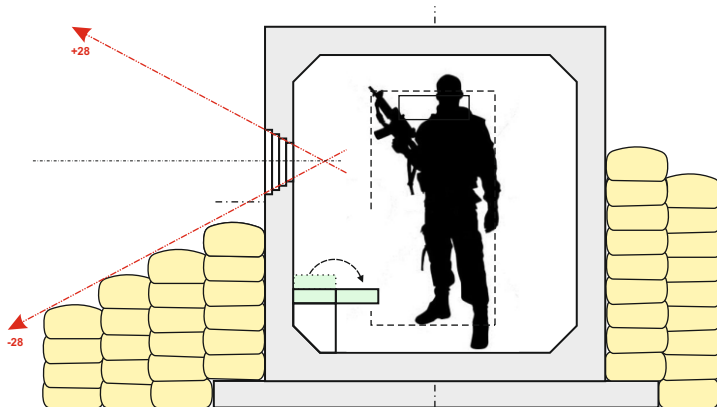

MOBILE BUNKERS.

A first-line position to slow or stop an enemy attack. Variable universal segments with stepped embrasures, slots, armoured doors, emergency exit and filter-ventilation system. Positioning of the Mobile Bunker in the field according to the tactical situation, turnkey configuration according to the client's specifications.

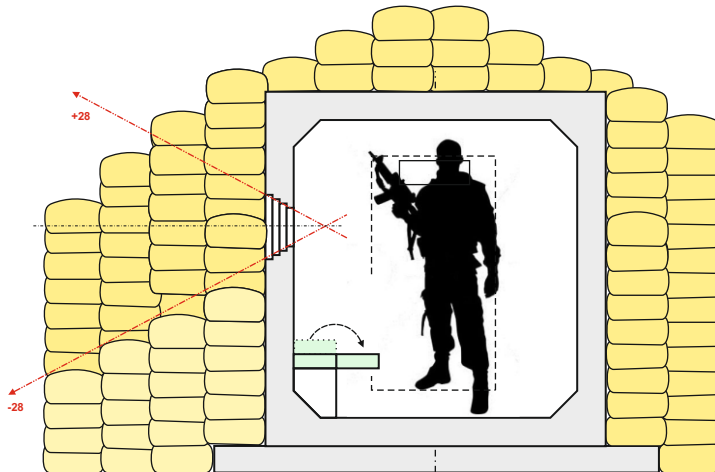

A sample of possible arrangements. Individually fitted segments with doors and escape hatch.

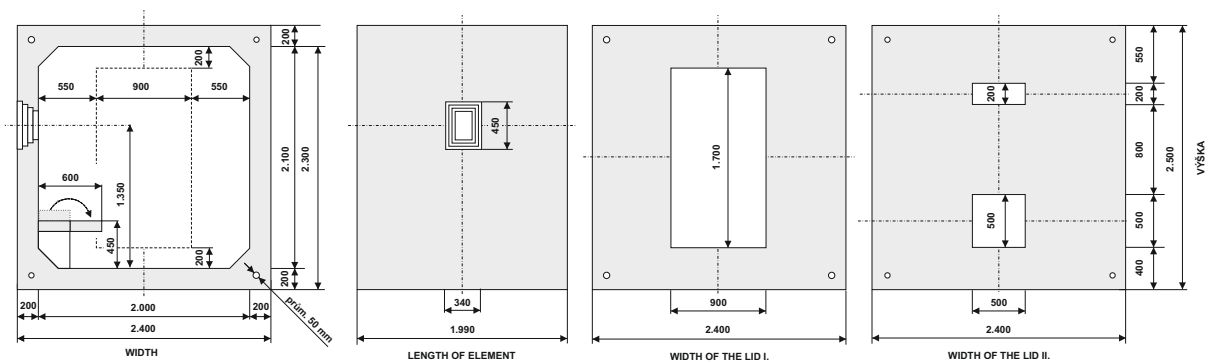
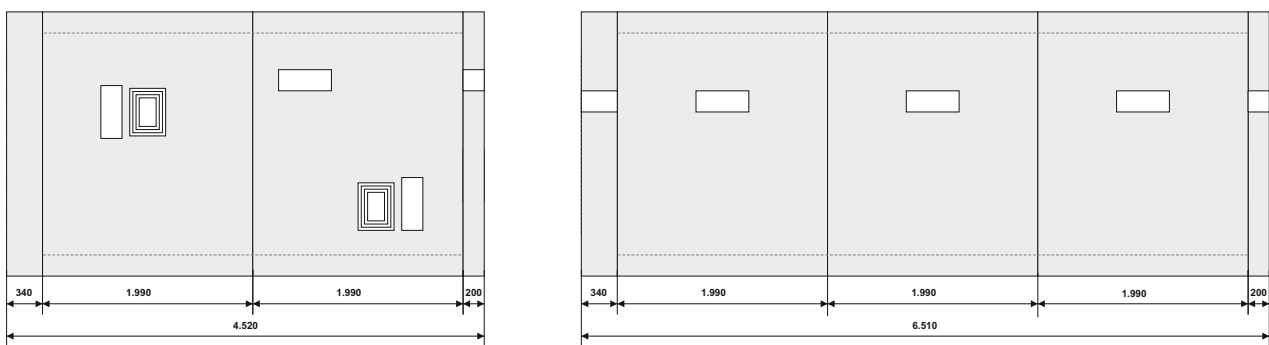

BASIC INFANTRY BUNKER. FOR THREE RIFLEMEN, TO PROTECT A SIX-MAN SQUAD.

A first-line position to slow or stop an enemy attack. A defensive mobile military fortification to protect a live force from drone attacks, artillery fire, grenades, and to waging a defensive fight on the line of defense.

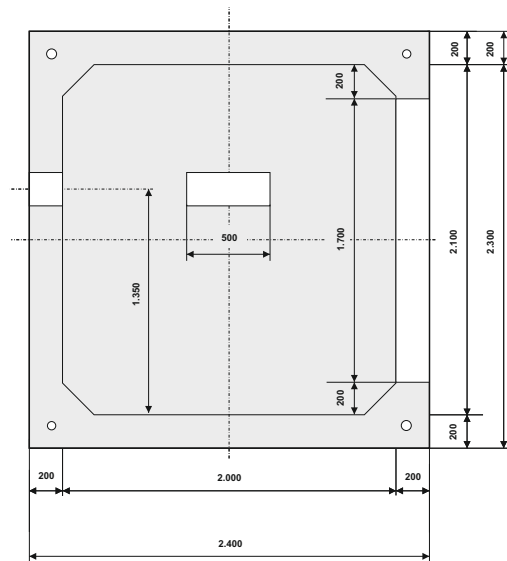
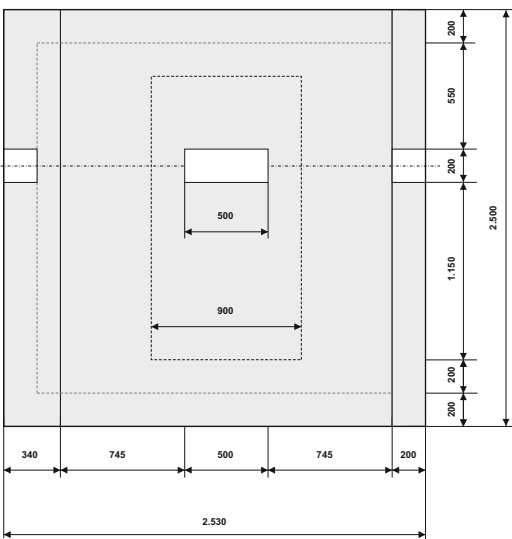
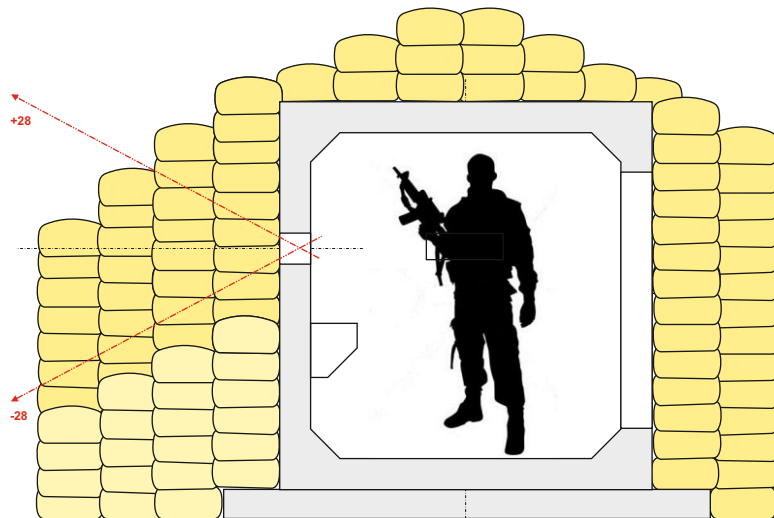

To increase the effectiveness of the protection, it is beneficial to partially embed it in the ground as part of the trench system and to reinforce the protection by lining it with natural material. Variably fitted universal building segment with embrasures, observations slits, entrance hole. Advantage of quick assembly and modular assembly to create a complex defence system.

EXTENDED INFANTRY BUNKER. FOR FOUR RIFLEMEN, TO PROTECT A 10-MAN SQUAD.

A first-line position to slow or stop an enemy attack. A defensive mobile military fortification to protect a live force from drone attacks, artillery fire, grenades, and to waging a defensive fight on the line of defense.

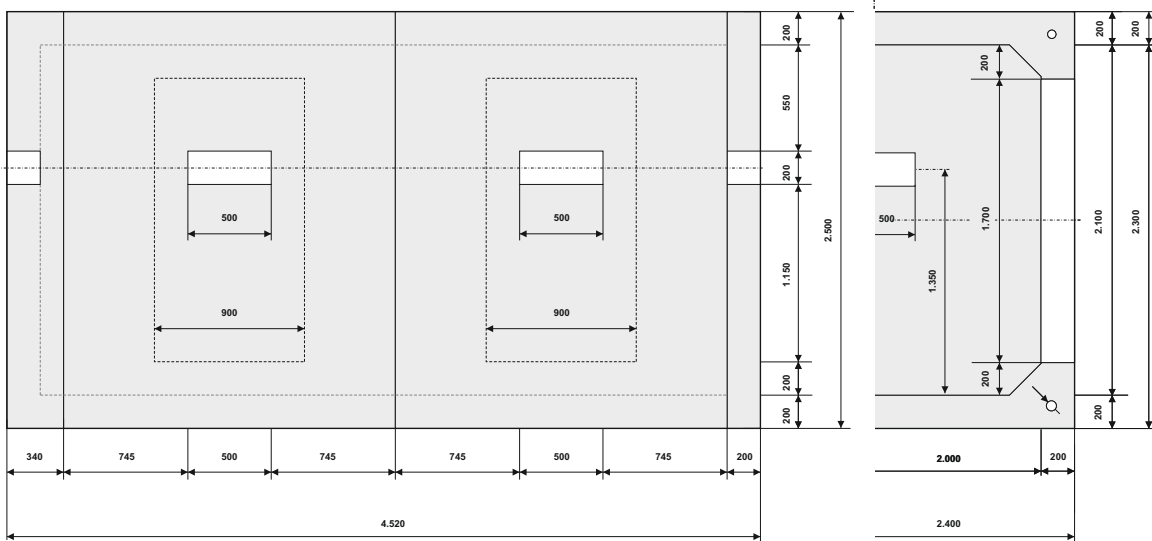
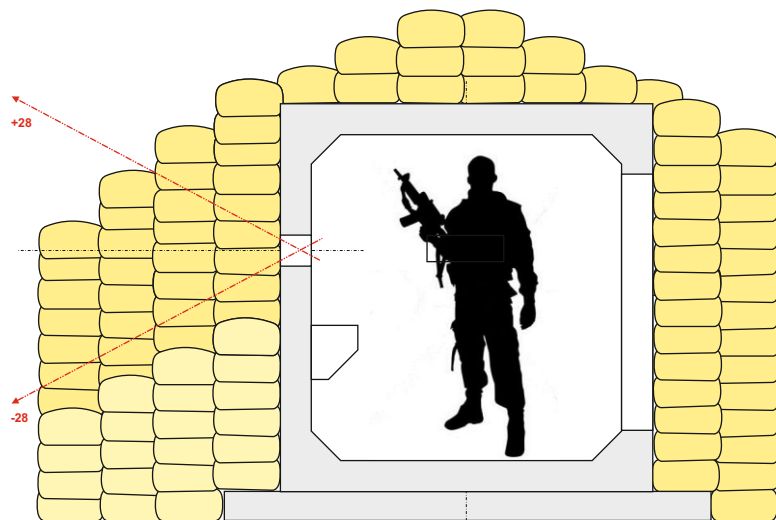

To increase the effectiveness of the protection, it is beneficial to partially embed it in the ground as part of the trench system and to reinforce the protection by lining it with natural material. Variably fitted universal building segment with embrasures, observations slits, entrance hole. Advantage of quick assembly and modular assembly to create a complex defence system.

AMMO BUNKER.

To safely store ammunition from drone attacks, gunfire, grenades and artillery fire. Three versatile construction segments form a tube enclosed on one side by a lid, open on the other side for quick access and handling. Without embrasures and observations slits.

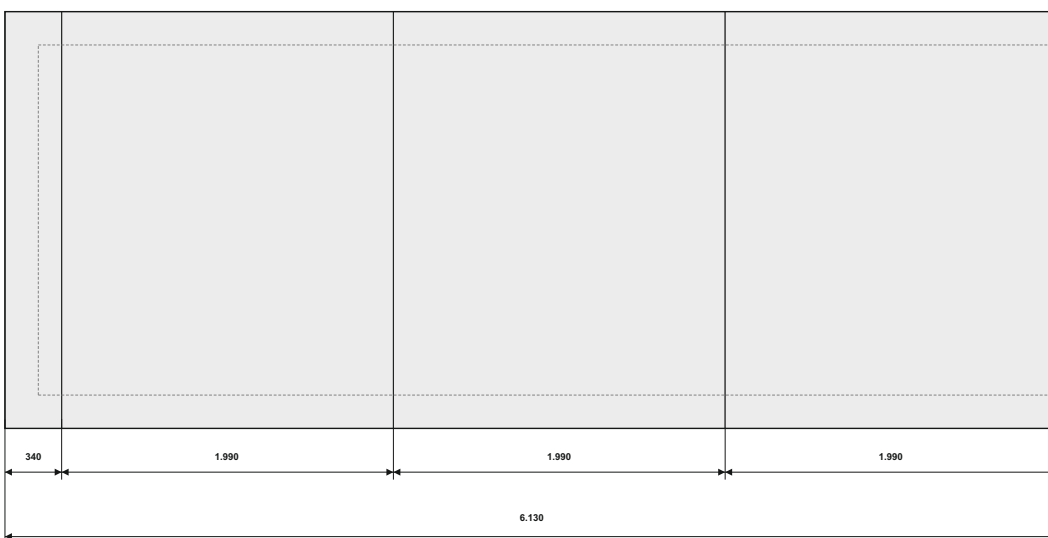
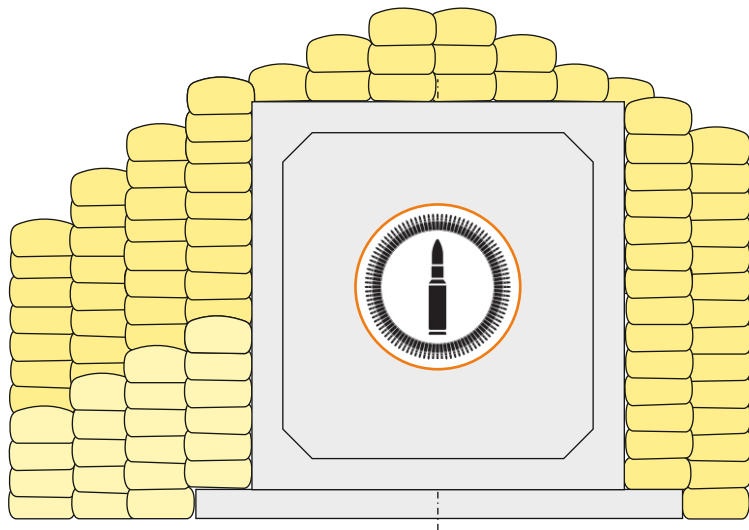

In the event of an explosion of the stored material, it directs the pressure wave out of the tubes, and reduce the risk of concrete fragments flying around. The 31.5 tonne capacity design provides additional restraining mass. The constructed sandbag containment berm will limit the velocity of projectiles, secondary shrapnel and pressure waves. Advantage of a quick assembly modular system.

MEDIC BUNKER.

A place designated for assembly for transport to a first aid site and subsequent medical care. To safely house wounded infantrymen and squad members, continuously available for cover to all squad members from drone attack, fire attack, artillery fire. Without embrasures and observations slits.

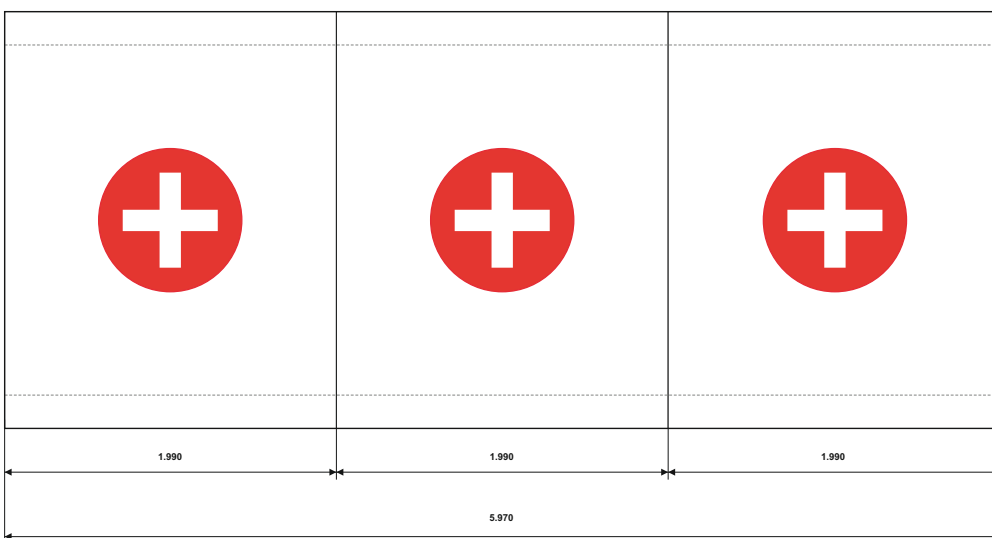
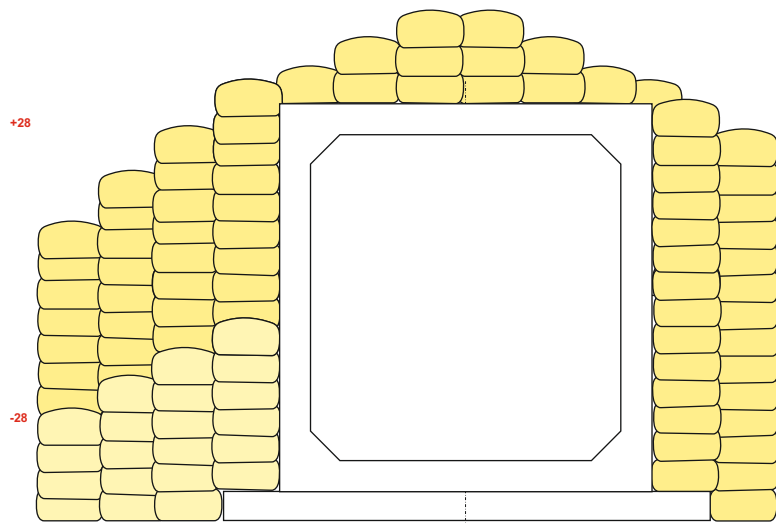

Three universal building segments form a pass-through tube for quick access and handling of the injured. The 27.5-tonne capacity design provides additional restraining mass. A protective sandbag berm around the Bunker limits the speed of missiles, secondary shrapnel and shock waves. The modular system has the advantage of quick assembly.

UNDERGROUND SHELTERS.

To protect against the effects of weapons of mass destruction. Against the pressure wave effects, penetrating radiation, radioactive contamination, chemical and biological warfare agents, industrial and incendiary substances, the thermal effect of fires, light and thermal emission, munitions shrapnel in explosions or collapsed building debris. With the FIRBACH 100 pressure filter-vent system, equipped with a CBRN filter, and anti-blast and overpressure valves.

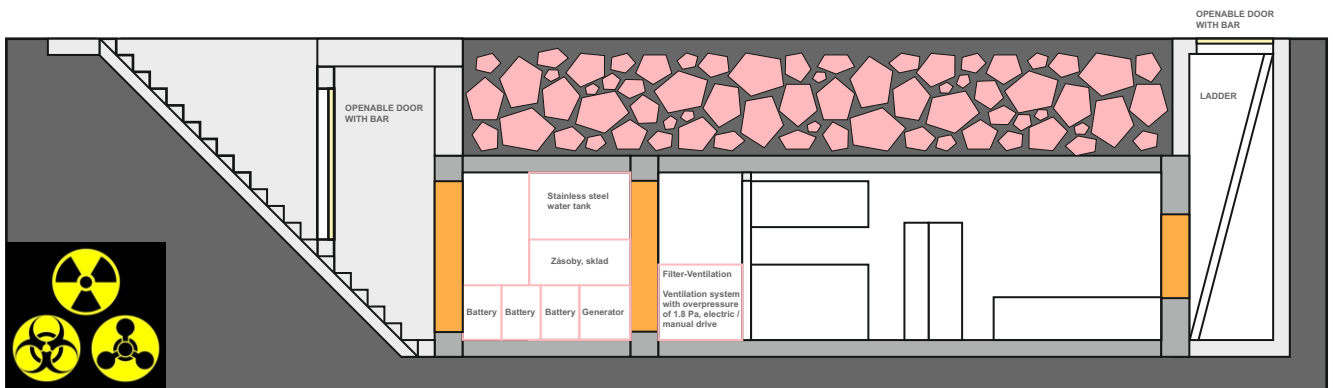

A sample of possible configuration. Five individually fitted segments with doors and escape exit.

- Patented UHPFRC composite material, certified for blast, ballistic and shrapnel resistance.
- High performance concrete C105/115, made according to EN 206; maximum resistance class.
- High-strength armoured doors.
- Barred doors made of high strength steel.
- Stone plane for protection against artillery fire or nuclear explosion with earthen backfill for camouflage.

FIRBACH 100. *Producer VZDUCHOTECHNIK s.r.o., member of Security Bunkers Alliance.*

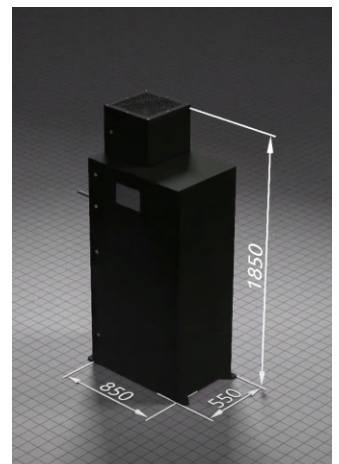
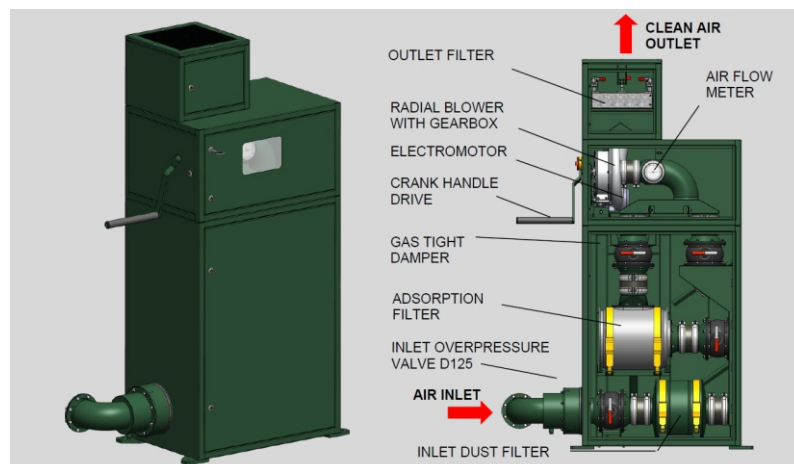

CIVIL DEFENCE SHELTERS.

Use as a means of sheltering civilians in the event of air attack or sniping by rocket troops and artillery. Location institutions, kindergartens and schools, hospitals, critical infrastructure, etc. Protection can be increased by covering with a sandbag or by placing in the ground.

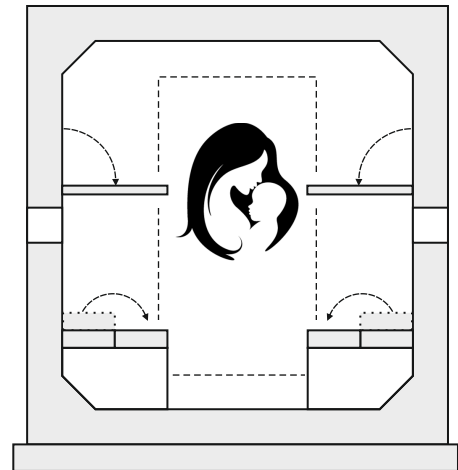

A sample of possible arrangements. Five individually fitted segments with doors and escape hatch.

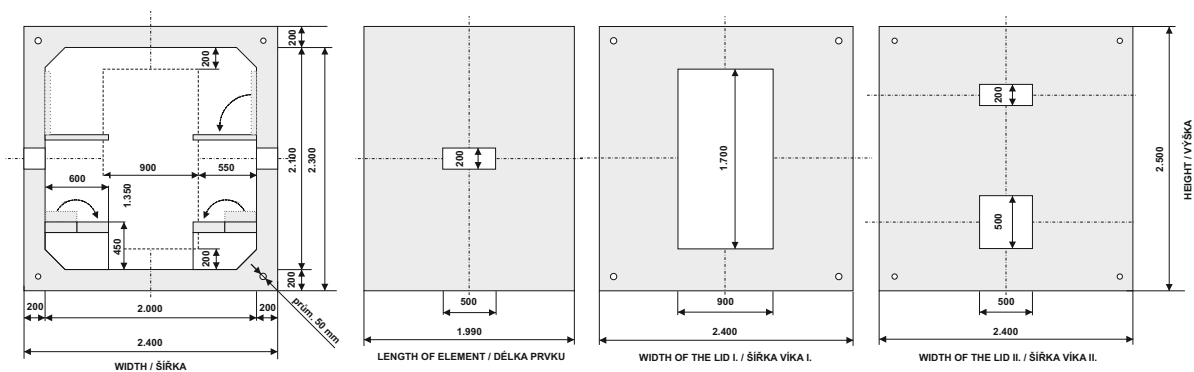
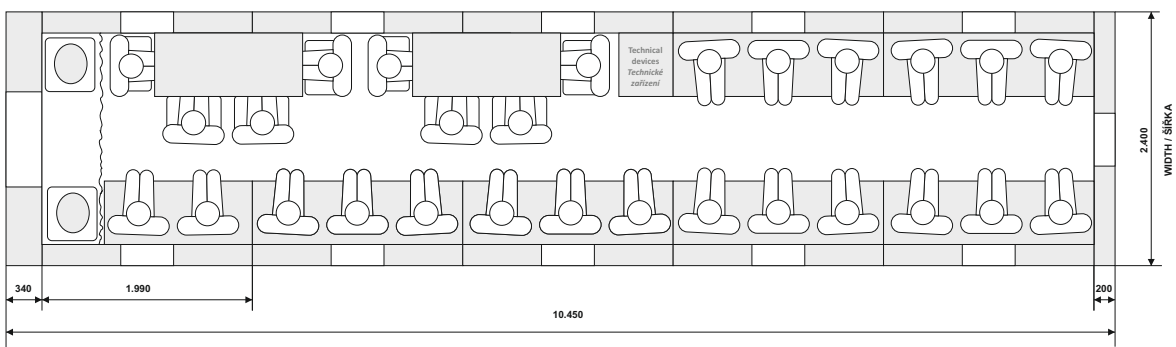

HARDENED AIRCRAFT SHELTERS.

To house and protect military fighter aircraft from enemy attack. To reduce the vulnerability of aircraft, to provide protection from CBRNE threats, to prevent by using satellites, aerial or drones reconnaissance to identify if aircraft are present.

Allow for safe aircraft maintenance in all weather conditions. Combined with active airfield defenses, it increases the survivability of aircraft, and the cost to the enemy of destroying them.



From the report by CTU Prague

Faculty of Civil Engineering, Department of Concrete and Masonry Structures.

High compressive strength of 150 MPa and tensile strength of 15 MPa, unique high ductility, ballistic A5 resistance, C4 shrapnel resistance, D6 blast resistance, zero radio transmission of waves, very high infrared shielding, and extremely high nuclear shielding properties gamma radiation in neutron emission are key factors and important parametric factors for the optimal design use of the patented UHPFRC as a material for Hardened aircraft shelters.

MOBILE T - WALLS.

For fast establish of a high level of security for military and civilian objects. For reinforce the defence of internal perimeters, access roads of urban centres, to control release points, before objects entrances or vehicle access control.

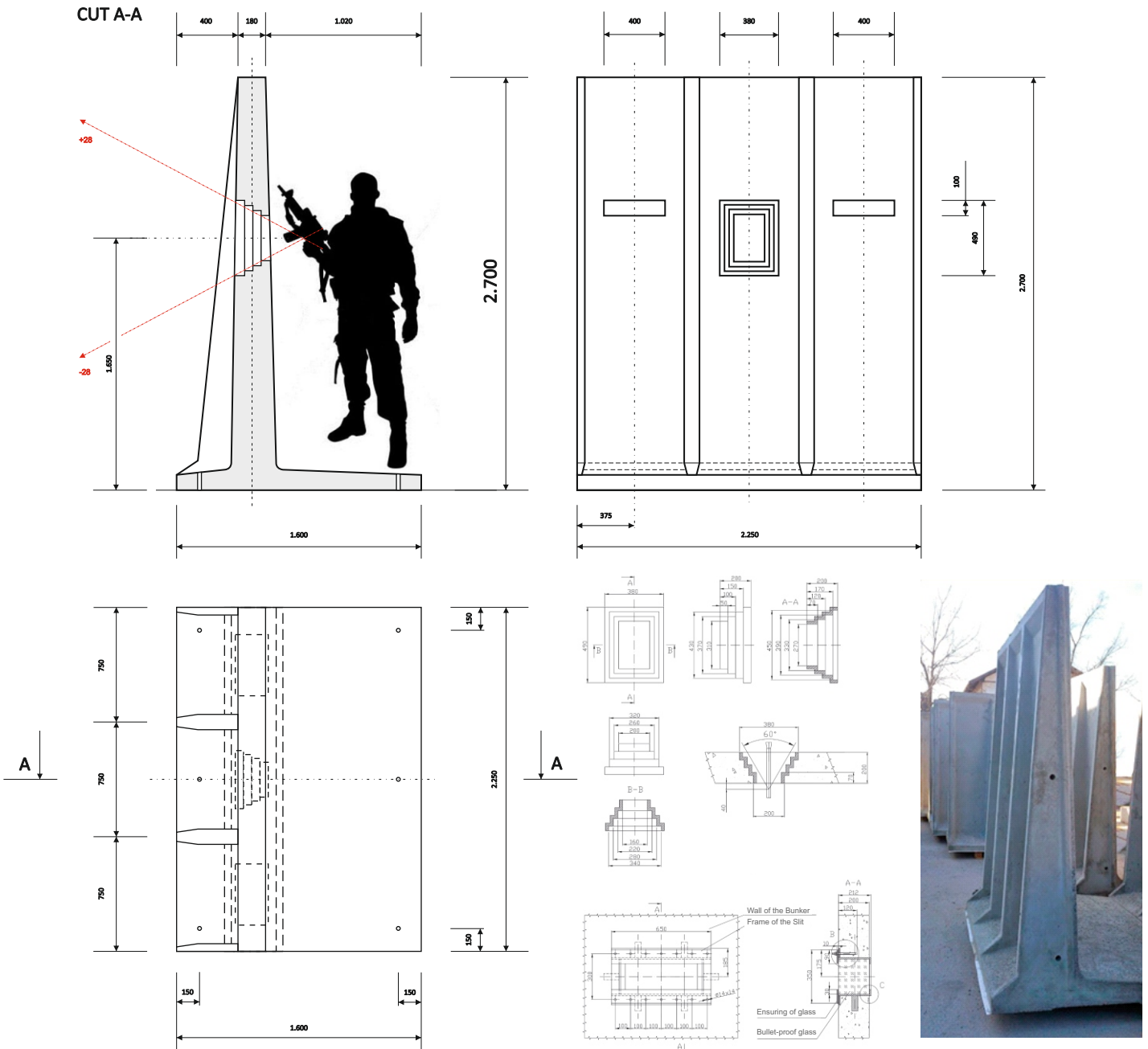

TUNNELS TO PROTECT HIGH PRIORITY CABLES.

A system used to protect power lines, fiber optic cables, IT sites, and IOT technology systems of critical military and civilian infrastructure.

WITH CONVEX OR FLAT LID



IN LIGHT AND HEAVY DESIGN

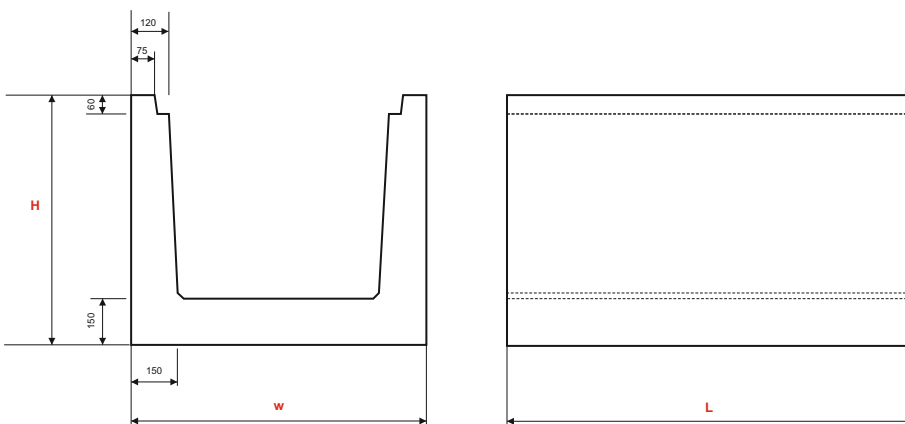

BALISTIC PLATES.

For reinforcing the walls of important infrastructure structures, military and public protection facilities.

LIGHT

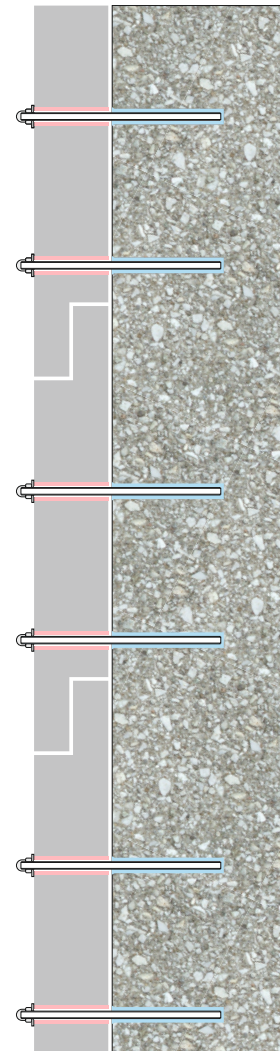
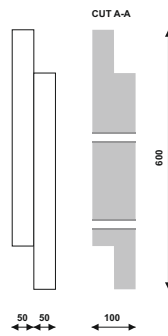
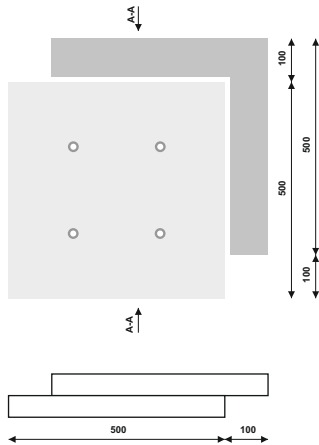

HEAVY

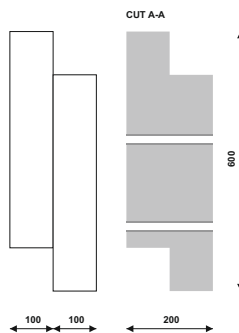
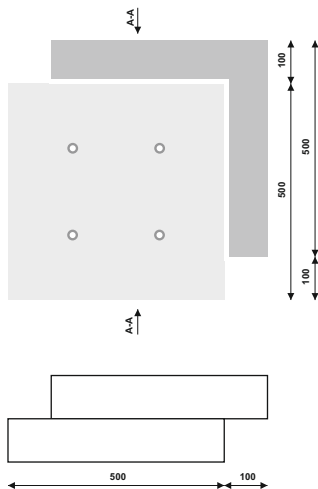



CONCRETE PYRAMID.

To create roadblocks on the state border, roadblocks on major transport arteries, access roads to urban agglomerations, important bridges and watercourses, access roads to objects of critical military and civil infrastructure.

HEAVY / MEDIUM / LIGHT.

All of elements are connected by a ship's shekel and a nautical anchor chain.

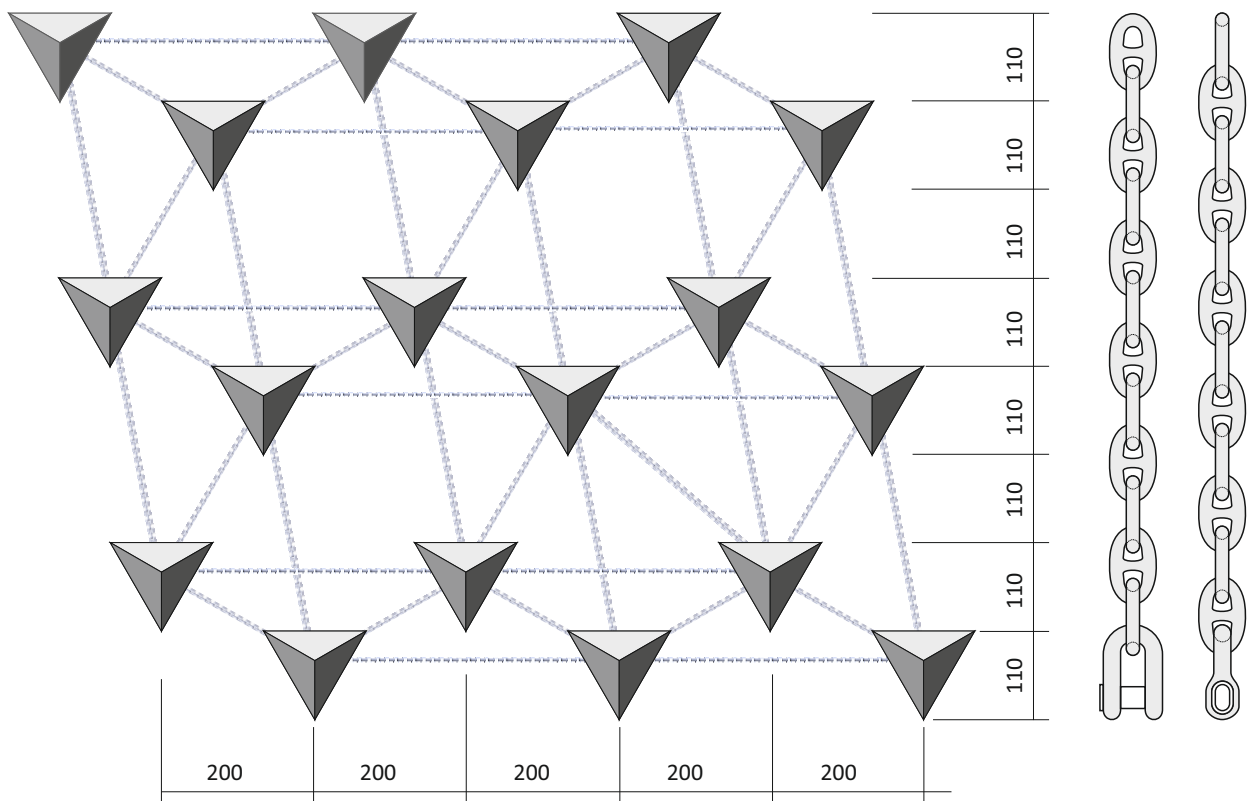
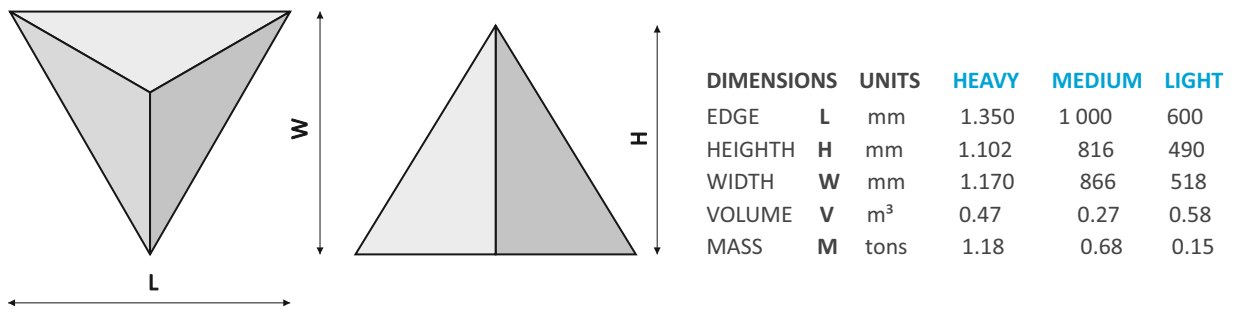

MOBILE ROADBLOCK – STING.

Mobile barrier elements for quick security of driveways, blocking traffic routes, preventing vehicles from entering, to control vehicles. Effective and easy to assemble mechanical security for use on any base material against cars, commercial vehicles, vans and heavy military equipment.

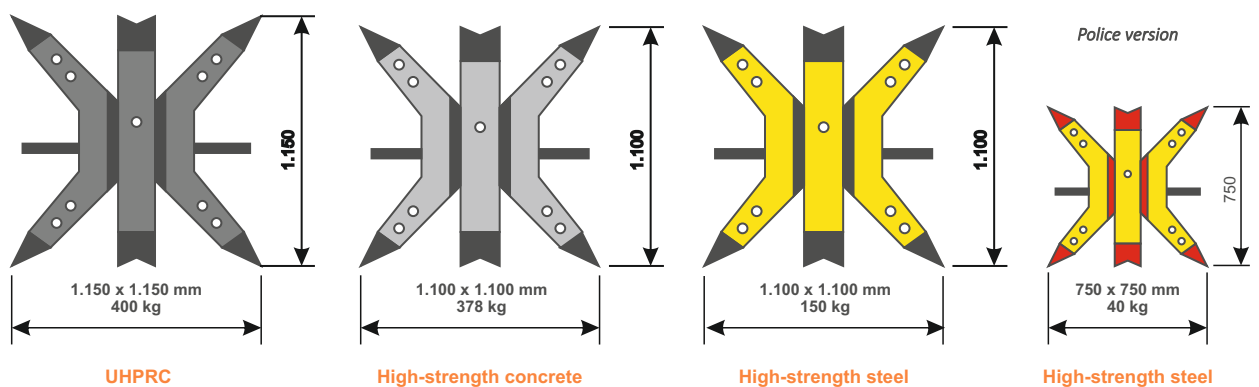

X HEAVY TANKS.



X MIDDLE TANKS.



X COMBAT VEHICLES, TRUCKS.



X CARS.

The Ministry of Defence and the Army of the CR have the elements listed in the register as **FOLDING BARRIERS** under Matl. Class. No. 0144110901003, 014545000003, 014545000027.

CONCRETE MIXTURES.

To quickly repair airport runways, bridges and roads.

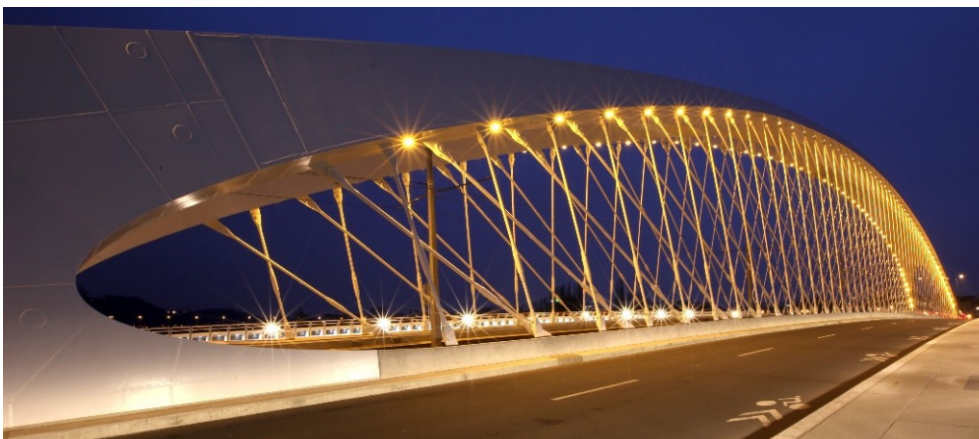



IBIPC

INSTITUTE OF BLAST &
IMPACT PROOF CONCRETE

MADE TO SAVE YOU



EXPERT LABORATORY OL 133
phone: 224 354 627
email: josef.fladr@fsv.cvut.cz

No. of copies: 5
Copy No.: 4
No. of pages: 3
Page No.: 1
No. of annexes: 0
No. of annexes pages: 0

Order No.: 8602152A000

TEST REPORT number: 133 003/2021

on testing:

COMPRESSIVE STRENGTH OF TEST SPECIMENS 133/3

Client's name and address:

JEAN-PAUL WHITECASTLE, spol. s.r.o.
Kaprova 42/14
110 00 Praha 1
VAT no.: 48041866

Date of test report issue:

17th December 2021



Approved by:

doc. Ing. Josef Fládr, Ph.D., Technical Manager OL 133

signature

*This test report can only be reproduced in its entirety, in part only with a written consent of the testing laboratory
The results of tests refer exclusively to the subject of the test (test specimen).*



www.ibipc.com



IBIPC

INSTITUTE OF BLAST &
IMPACT PROOF CONCRETE

MADE TO SAVE YOU

Vojenský výzkumný ústav, s. p.
Veslařská 230, 63700 Brno, Česká republika

CERTIFICATE
Nr. VVÚ 2280-011-2022

Client: **JEAN PAUL WHITECASTLE, spol. s r.o.**
Kaprova 42/14
110 00 Praha 1 – Staré Město

Manufacturer: **INSTITUTE OF BLAST & IMPACT PROOF
CONCRETE, s. r. o. (IBIPC)**
Jihlavská 2512/34,
591 01 Žďár nad Sázavou

Product: **UHPFRC**
The material composition of the samples is in accordance
with Patent of CVTU Prague No. 304 478 and with
European Patent of CVUT Prague No. EP 3 351 518 A1.

Testing Equipment: 1 pc sample (500 x 500 x 200 mm)
1 pc basic part of the bunker (2400 x 2400 x 200 mm)

Classification Level: **A5, C4 and D6 according to STANAG 2280
Edition 2 / ATP-3.12.1.8, Edition 1, Version 1**

The validity of the Certificate is related to the Test Reports from the Physical Tests of UHPFRC samples No. VVU-SMI-22-101, VVU-SMI-22-102 and VVU-SMI-22-103 where tested UHPFRC samples are specified.

The testing Equipment is Conditionally Compliant with the protection level A5, C4 and D6 according to STANAG 2280 Edition 2 / ATP-3.12.1.8, Edition 1, Version 1.

Brno, January 30th 2023

Vojenský výzkumný ústav, s.p.
Veslařská 230, 637 00 Brno
DIČ: CZ29372259, IČ: 29372299

Ing. Pavel ČUDA, Ph.D.
director



TESTED AND CERTIFIED BY A MILITARY RESEARCH INSTITUTE.



BULLET 12.7 x 99 API M8 / 14,5 x 114 API M32. FRAGMENTATION INCENDIARY TO PENETRATE ARMOR.
*For heavy machine gun and anti-tank rifle cartridge. AP - Armour Piercing. Impact velocity 900 m/s.
Against armoured targets.*



ROCKET 107 MM/MIN MORTAR GRENADE 120 MM. FROM A DISTANCE OF 1,5 M.
*The mortar 120 mm round is designed for firing at unprotected stationary targets, high concentrations
of enemy troops, transport convoys or machine gun nests.*



EXPLOSIVE CHARGE 20 KG TNT. FROM A DISTANCE OF 5 M.
*The explosion causes a sudden, very violent release of energy, and a sharp local increase temperature
and pressure; it creates an air pressure wave. The dynamic pressure destroys and burns everything.*

Mgr. Pavel Belohradsky
CEO | INSTITUTE OF BLAST & IMPACT PROOF CONCRETE
pavel.belohradsky@ibipc.com | +420 777 32 38 36 | www.ibipc.com

NATO - STANAG 2280 : 2016 STANDARDS.

BY NATO - ATP-3.12.1.8 TEST PROCEDURES AND CLASSIFICATION OF THE EFFECTS OF WEAPONS ON STRUCTURES

STANAG 2280, Ed. 2.

	A	B	C	D	E	
	Projectiles	Direct Fire Warheads	Indirect Fire Munitions	High Explosive (TNT Eqvt)	Moving Vehicles	
Severity of Effect (level)	6.	Automatic canon 30 mm APDS	Advanced ASM Anti Structure Munitions	240 mm Rocket	≤ 50 kg	Tracked Vehicle
	5.	HMG 14.5 mm (0.57)	Tandem ASM	155 mm Mortar 122 mm Rocket	≤ 10 kg	Large Truck ≤ 32,000 kg
	4.	HMG 12.7 mm (0.50)	Anti-personel Thermobaric conventionalcharge < 2.5 kg	120 mm Mortar 107 mm Rocket	≤ 2 kg	Truck ≤ 7,500 kg
	3.	Assault / Sniper Rifle 7.62 mm AP	Anti-tank Shaped charge	82 mm Mortar	≤ 1 kg	Small Truck ≤ 2,500 kg
	2.	Assault Rifle 5.56 - 7.62 mm Ball	40 mm Rifle grenade shaped charge	60 mm Mortar	≤ 0.5 kg	Passanger Car ≤ 1,500 kg
	1.	Pistol	(reserved)	Hand grenade	≤ 0.1 kg	Motorcycle

This ATP covers:

a. Common military projectiles, fragmentation, vehicle and blast weapons, as well as a generalized spectrum of blast threats, which includes the characteristics of the majority of Improvised Explosive Device (IED) attacks.

b. The effects of weapon systems on infrastructure, including the following:

(1) Blast;

(2) Penetration:

i. Bullets and penetrators;

ii. Shaped Charges;

iii. Vehicles;

(3) Fragmentation;

(4) Secondary Effects (including spalling and fire).



IBIPC

INSTITUTE OF BLAST &
IMPACT PROOF CONCRETE

MADE TO SAVE YOU

www.ibipc.com

